

APPLICATION:

PRODUCT NAME:

DrainKing WASTE VALVE

JOB NAME:

_____ SPECIAL CONFIGURATION
(CHECK BASE MODEL AND OPTIONS)

QUANTITY:

ITEM NO.:

MODEL:

- 22373 w/ VR FLAT STRAINER & KNOB.
& 19" X 21" OVERFLOW
- 22381 w/ VR FLAT STRAINER & KNOB.
& 14" X 16" OVERFLOW

OPTIONS OR MODIFICATIONS:

OTHER _____

FEATURES:

- * DUAL TEFLON SEALS
- * STAINLESS STEEL BALL
- * CAST RED BRASS BODY
- * EXTRA SURDY STAINLESS STEEL CLAMPING RING
- * "CLEAR THROUGH" OPENING, NO NEED TO DISASSEMBLE IF SNAKING IS REQUIRED
- * INDUSTRY STANDARD "SEALING" ANGLE - FITS FLUSH TO STANDARD STAINLESS STEEL SINKS
- * VANDAL RESISTANT STAINLESS STEEL FLAT STRAINER
- * VANDAL RESISTANT KNOB
- * 1/4 TURN FULLY OPENS AND CLOSES VALVE
- * SUPPLIED WITH:
ALTERNATE LEVER HANDLE

DRAIN RATE:

- * 12 GPM

SHIPPING WEIGHT

- * 10.0 LBS

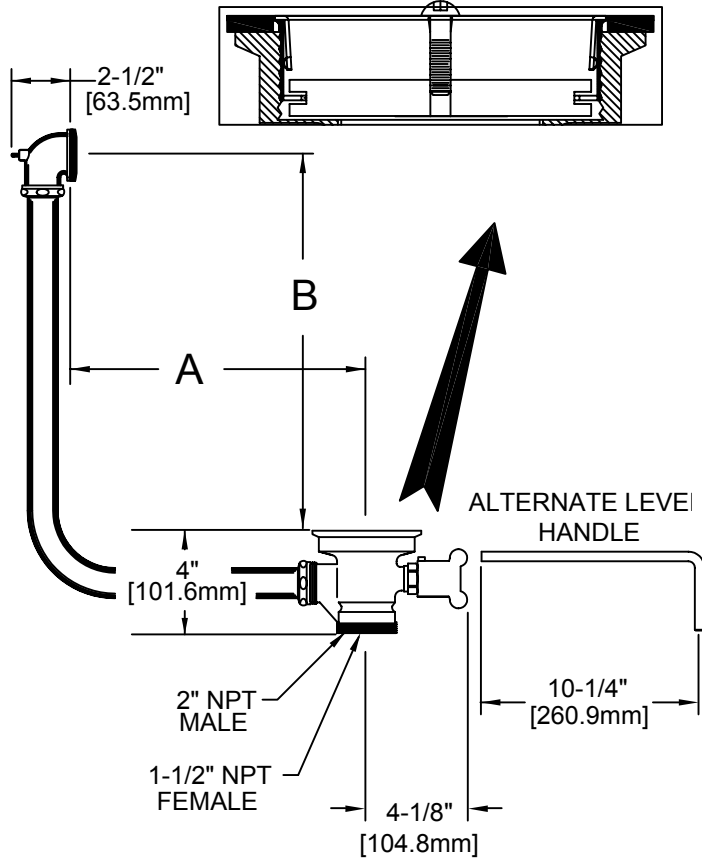

MODEL	19" X 21"	
	DIM "A"	DIM "B"
22373	19" [482.6mm]	19-1/4" [489.0mm]

MODEL	14" X 16"	
	DIM "A"	DIM "B"
22381	14" [355.6mm]	14-1/4" [362.0mm]

ROUGH-IN:

OVERFLOW



Ø1-5/8"
[41.3mm]

DRAIN

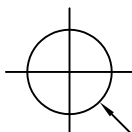

Ø3-1/2"
[88.9mm]



ANSI/A112.18.1M

FISHER

FISHER MANUFACTURING COMPANY

TOLL FREE: 800-421-6162 - FAX: 800-832-8238

information@fisher-mfg.com - www.fisher-mfg.com